

# Is Optical Multilayer Networking Feasible?

George N. Rouskas

Department of Computer Science

North Carolina State University

<http://rouskas.csc.ncsu.edu/>

# In the Beginning ...

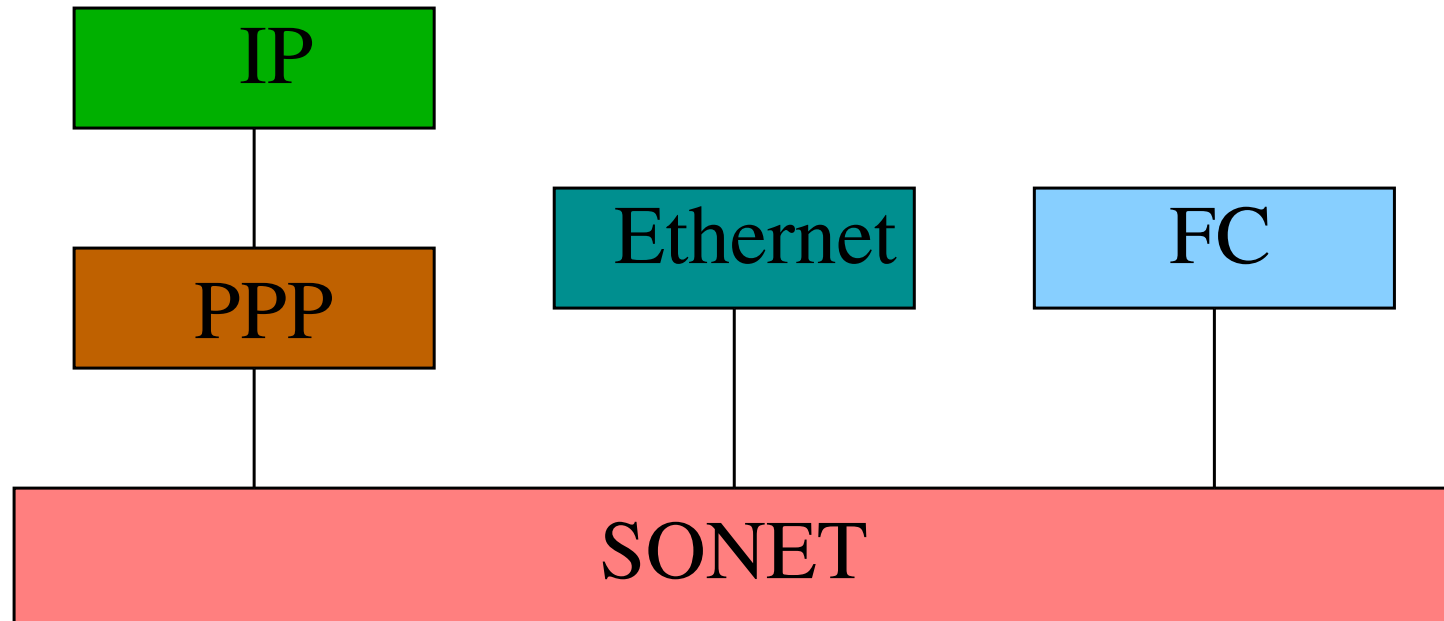

# And The Users Were Not Happy ...

# And The Users Were Not Happy ...

and went to the Net Engineers with many lamentations and demands:

# And The Users Were Not Happy ...

and went to the Net Engineers with many lamentations and demands:

- interoperability
- faster speeds
- QoS
- QoP
- ...

# And The Users Were Not Happy ...

and went to the Net Engineers with many lamentations and demands:

- interoperability
- faster speeds
- QoS
- QoP
- ...

and the Net Engineers went to work, and toiled through the bubble

# How Far We've Come ...

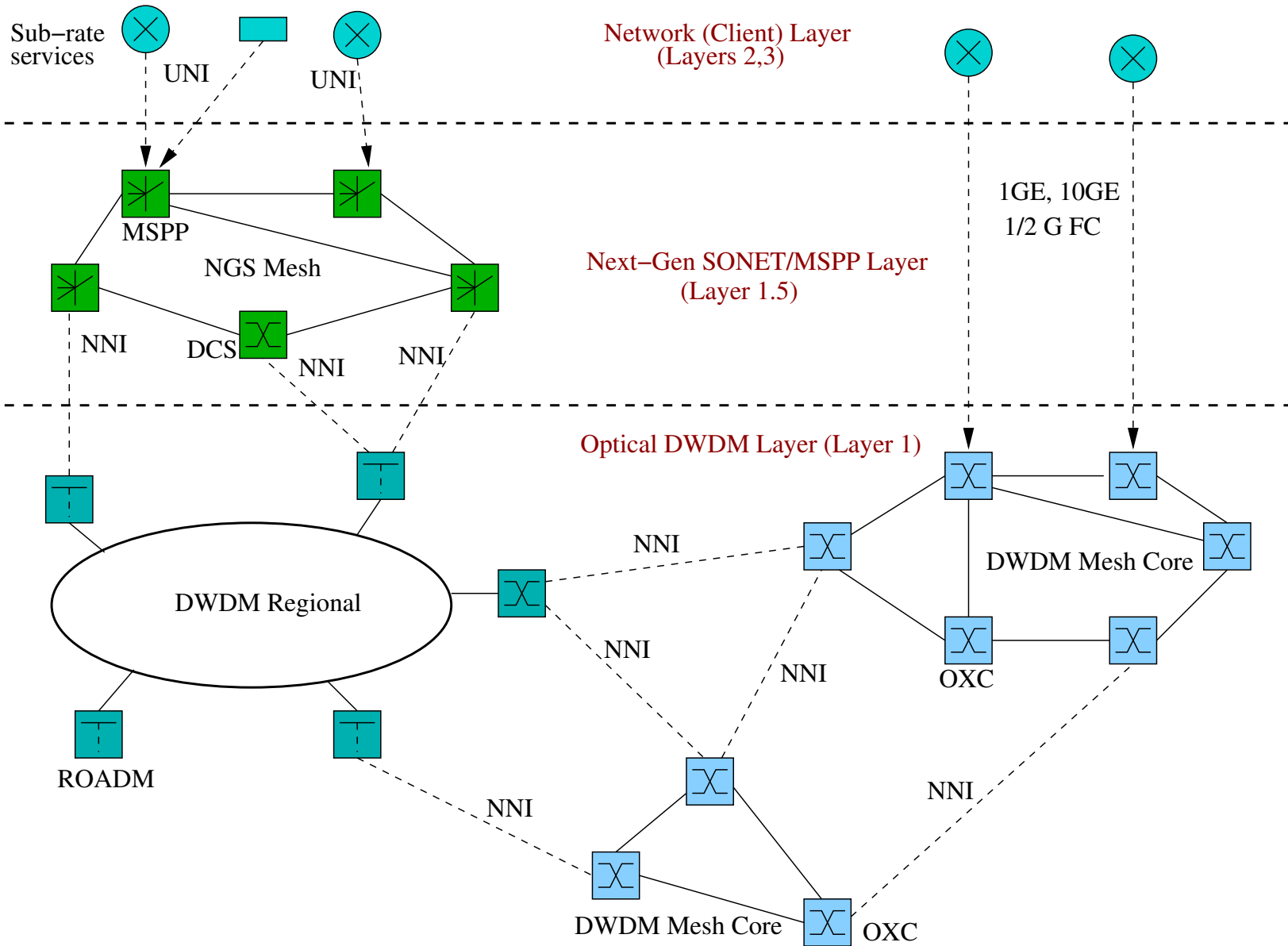

# How Far We've Come ...

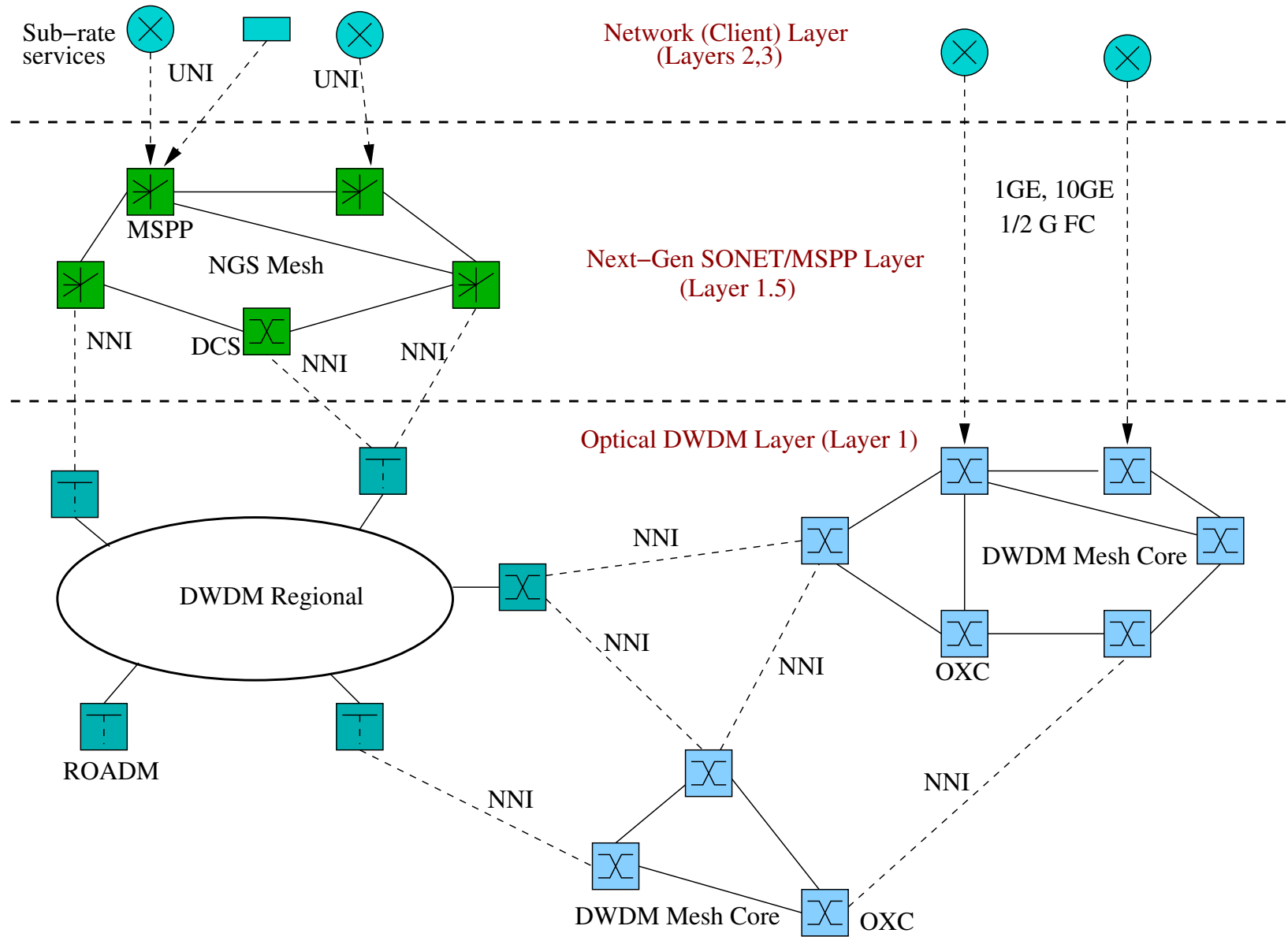



# How Far We've Come ...

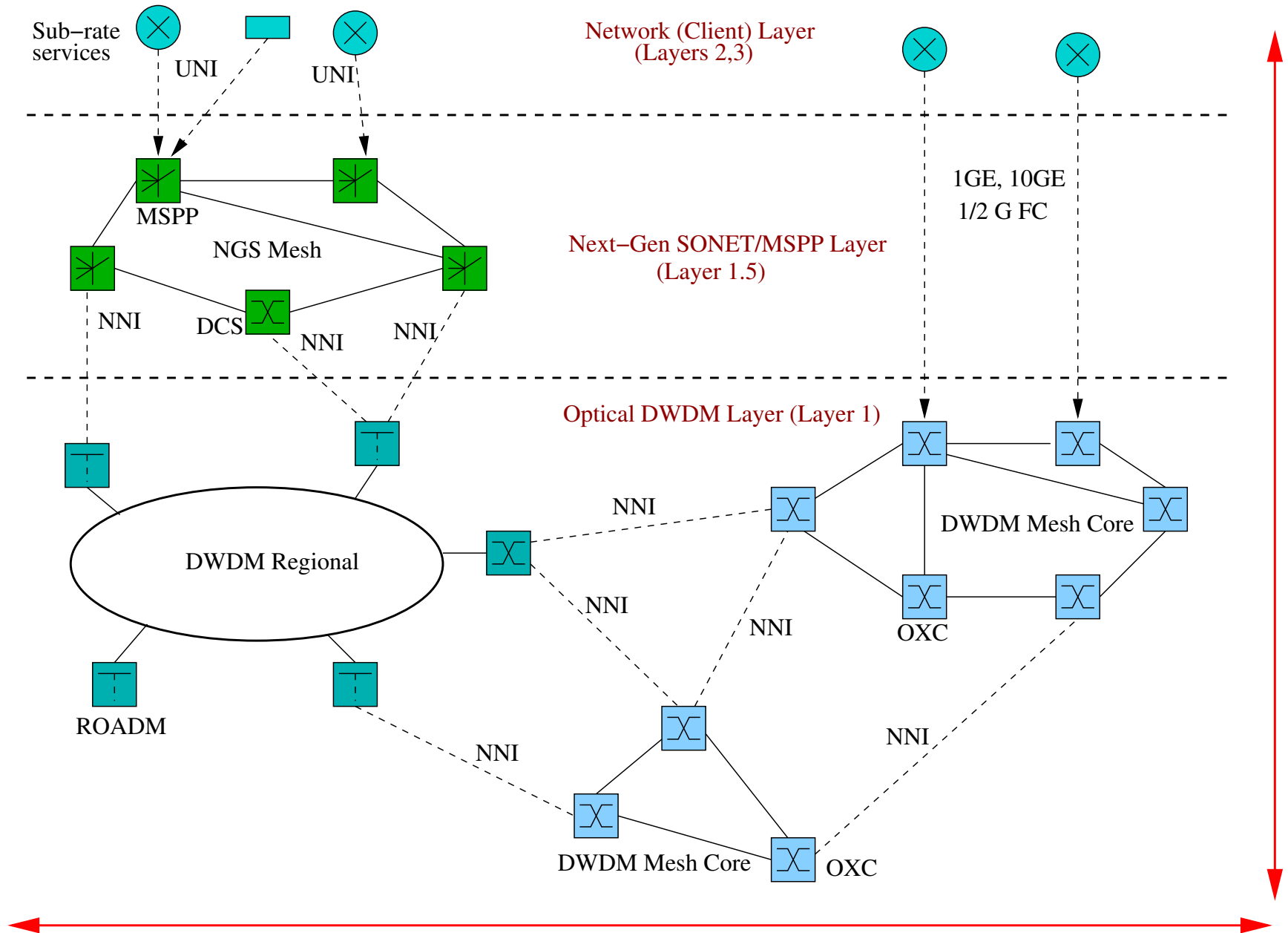

# Cross-Layer Interactions: Network Resiliency

- Single-layer only
  - bottom layer: too coarse, cannot handle higher layer failures
  - top layer: too fine, may require lots of recovery actions

# Cross-Layer Interactions: Network Resiliency

- Single-layer only
  - bottom layer: too coarse, cannot handle higher layer failures
  - top layer: too fine, may require lots of recovery actions
- Multi-layer strategies:
  - no coordination
  - escalation strategy: bottom-up or top-down
    - hold-off timer
    - token passing

# Cross-Layer Interactions: Network Resiliency

- Single-layer only
  - bottom layer: too coarse, cannot handle higher layer failures
  - top layer: too fine, may require lots of recovery actions
- Multi-layer strategies:
  - no coordination
  - escalation strategy: bottom-up or top-down
    - hold-off timer
    - token passing
- Cross-layer approach: integrated design
  - each layer must be aware of working/spare capacity of the other
  - dynamic, coordinated logical topology modification

# So Where Do We Stand?

- Layering: separation of concerns → too limiting today
- No good way for bi-directional information exchange between layers
- Cross-layer solutions difficult today
  - engineered within constraints of layering
  - only apply to specific context

# So Where Do We Stand?

- Layering: separation of concerns → too limiting today
- No good way for bi-directional information exchange between layers
- Cross-layer solutions difficult today
  - engineered within constraints of layering
  - only apply to specific context

We are back where we started !!!

# So Where Do We Stand?

- Layering: separation of concerns → too limiting today
- No good way for bi-directional information exchange between layers
- Cross-layer solutions difficult today
  - engineered within constraints of layering
  - only apply to specific context

We are back where we started !!!

Attend my talk tomorrow :-)

# Will You Have (Fried) Packets with That?

Issues even at the data plane:

- burst-mode transceivers → Matisse Networks?
- buffers → data vortex?
- $\leq \mu s$  switching



# Circuits *And* Packets (1)

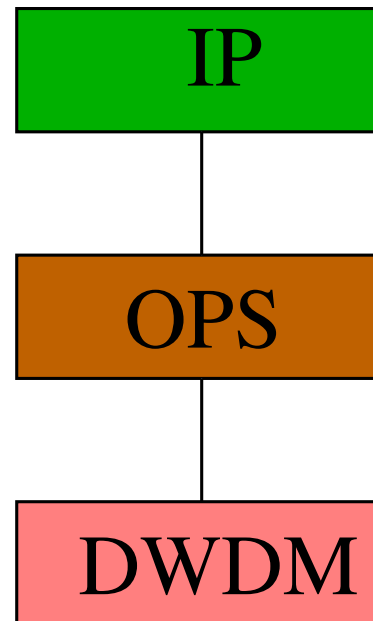

# Circuits *And* Packets (2)

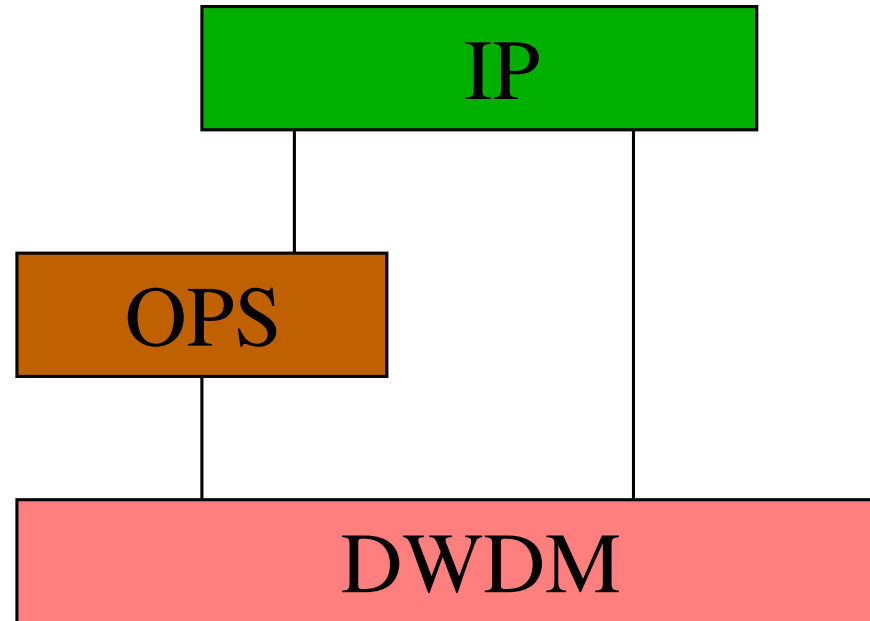

# Circuits *And* Packets (3)

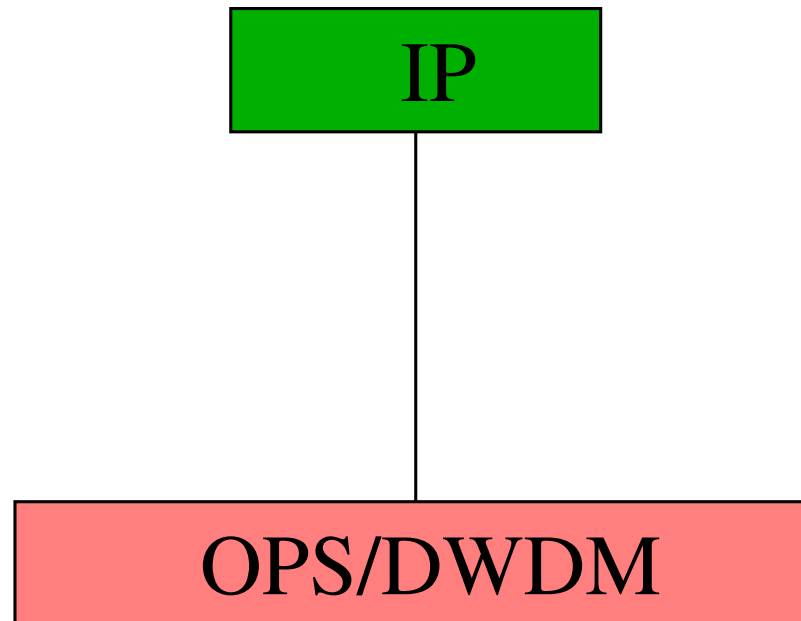

# A Note on OBS

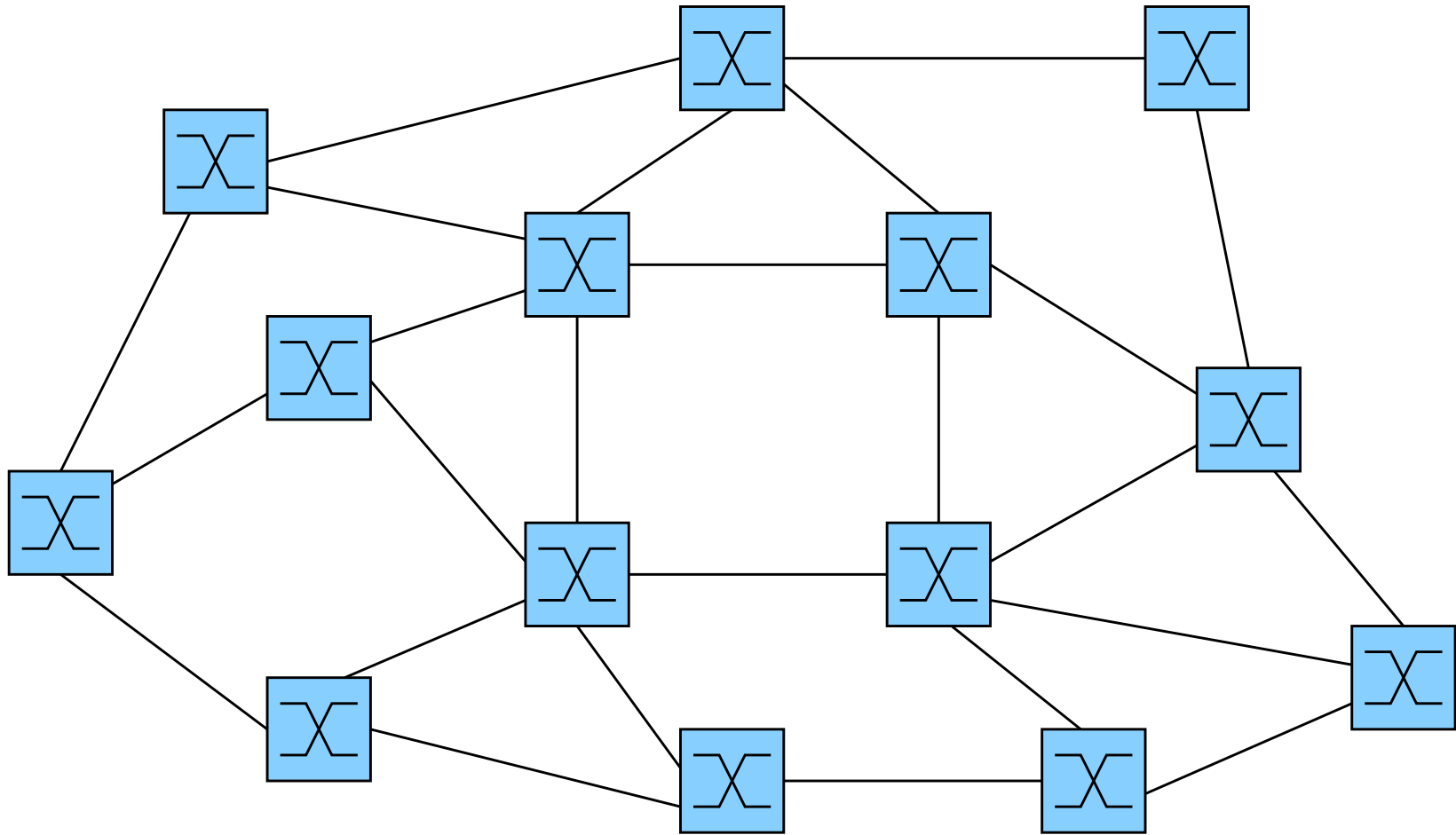

# A Note on OBS

